

**PERFORMANCE[®]
FRICTION
BRAKES**



Carbon Metallic[®]

PORSCHE BRAKE APPLICATIONS



**FAST ROAD & TRACK DAY BRAKE UPGRADES
RACE DISCS AND PADS**

PERFORMANCE FRICTION BRAKES



PORSCHE BRAKE APPLICATIONS



Carbon Metallic®

PADS

APPLICATION	MODEL	YEAR	FRONT	REAR
C	356	63 - 65	0031	-
2.2 / 2.3	911	72 - 83	0045	0031
3.3 SC Turbo Turbo Sport	911	77 - 90	0345	0345
2	924	79 - 87	0252	-
4.5	928	78 - 85	0252	-
S	928	80 - 85	0395	-
4.7	928	81 - 85	0253	-
S & S4 & GT	928	85 - 95	0447	0345
5.4 GTS 32V	928	91 - 95	0594	0345
2.5 Turbo	944	85 - 87	0345	0345
2.5 Turbo	944	87 - 91	0447	0345
2.7 & 3.0 S2	944	88 - 91	0345	0345
2.5 Turbo	944	87 - 91	0447	0345
2.8	959	87 - 91	0594	0594
C2 3.6	964	88 - 91	0345	-
C2 3.6	964	91 - 94	0345	0345
3.6 C4	964	88 - 94	0345	0345
3.6 Carrera RS	964	91 - 93	0447	0345
3.3 Turbo & Turbo S	964	88 - 91	0447	0345
3.3/3.6 Turbo/Turbo S	964	91 - 93	0594	0345
3.0 Coupe	968	91 - 95	0345	0345
3.0 Coupe Sport	968	91 - 95	0447	0345
3.0 Coupe Turbo S	968	93 - 95	0594	0345
3.6 Carrera & C4	993	93 - 97	0447	0345
3.8 Carrera & C4	993	95 - 97	0447	0345
3.6 Turbo & Turbo GT2	993	95 - 97	0594	0447
3.8 Carrera RS & RSR	993	95 - 97	0594	0447
GT2 & RSR (380 disc)	993	95 - 97	0594	0447
3.4C & 3.6	996	97 - 05	0776	0738
C4 S	996	01 - 04	07818	0776
3.4C Super-Cup	996	97 - 98	0594	0776
3.4C Super-Cup	996	99 - 01	7818	0776
GT3 R & GT3 RS	996	00 - 05	0594	7700
GT3 & 996 Turbo	996	99 - 01	7818	0776
Turbo	996	02 - 04	7818	0776
GT3	996	02 - 04	7819 / 0991	0776
GT3 Super-Cup	996	02 - 04	7819 / 0991	0776
Carrera GT	996	04 -	7819 / 0991	0776
GT2	997	02 -	7819 / 0991	0776
997	997	05 -	0776	0776
997 S	997	05 -	7819 / 0991	0776
Turbo	997	06 -	7819 / 0991	1299
GT3	997	06 - 10	7819 / 0991	1299
GT3 RS	997	06 -	7819 / 0991	1299
GT3 CUP	997	05 -	7819 / 0991	1299
GT 3	997	2010 -	7819	1299
GT3 RSR	997	07 -	7797	7700
Boxster	986	96 - 05	0737	0738
Boxster S	986	99 - 05	0776	0738
Boxster	987	05 -	0737	0738
Boxster S	987	05 -	0776	0738
Cayman, S, R	987	06 -	0776	0738

PORSCHE BRAKE APPLICATIONS

PAD COMPOUNDS



Carbon Metallic®

2011 Production Performance Friction Compounds - listed in the order of highest bite and torque

01 has high initial bite and torque with very little torque rise with temperature. It has less torque scatter at the end of the stop for improved modulation. 01 Compound has good disc conditioning properties with low wear. 01 Compound is one of PFC's most popular race compounds, and wins more World and National Championships annually than any other brake pad on the market. Recommended for a wide range of competition applications, both tarmac and gravel surfaces.

06 has been designed as an endurance / sprint compound and is very similar to PFC 01 for both bite and torque, with excellent release and control with very low wear and very easy on brake discs. 06 pads are an excellent alternative to other brands of endurance compounds but give a much higher performance. This compound works well in both motorsport and OE type calipers even when ABS systems are retained.

08 compound is one of PFC's newest and has gained immediate favour in extended Endurance Sportscar, and GT racing due to its performance in applications where smooth initial bite is a must. 08 has a slight friction rise with temperature, excellent release and modulation characteristics. Very low disc wear, similar to 01. Despite its considerable performance, 08 has the lowest wear rate of all PFC compounds and can easily match the wear characteristics of the other competitor's materials but with much higher bite.

97 Compound has less initial bite and average torque than 08. It has great modulation, a very flat torque curve, and enhanced release characteristics. 97 is recommended as a general-purpose pad for Club Racing and Track Day events. This compound also works well in the rear when a higher torque front pad is chosen but a very stable consistent low torque rear pad is required. 97 compound can produce higher levels of dust at elevated temperatures.

Z-Rated .10 / .11 - this compound has been designed for fast road / trackday applications. It gives more stopping power and increased fade resistance over the OE materials but retains the good qualities of the road pad i.e., low dusting and noise along with low wear rate.

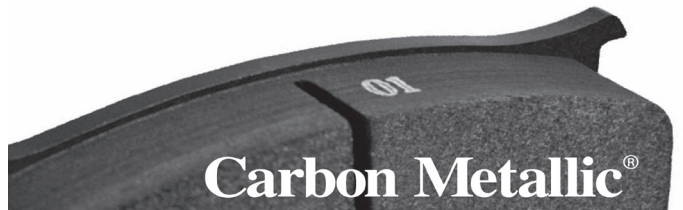

PAD PROFILES

PAD COMPOUNDS AVAILABLE

PART NUMBERING AS FOLLOWS:

Pad Shape **0031** Compound **.97** Total Thickness **.15 (mm)**

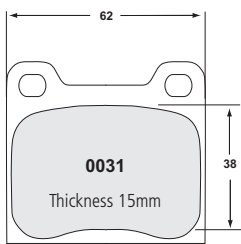

COMPOUNDS
.97

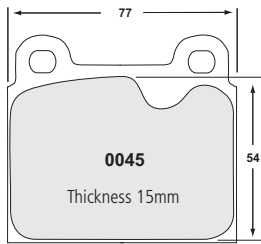

COMPOUNDS
.01 - .97

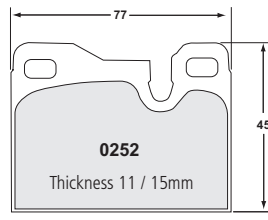

COMPOUNDS
.01 - Z-Rated

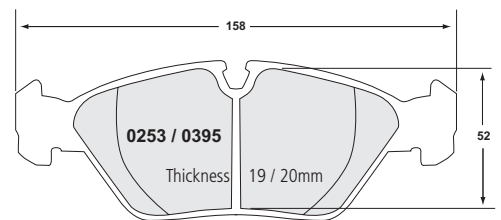

COMPOUNDS
.01 - .06 - .97 - Z-Rated

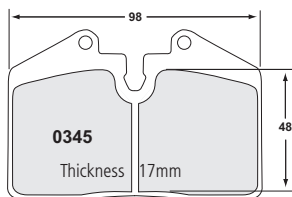

COMPOUNDS
.97

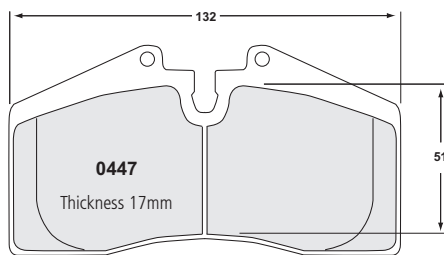

COMPOUNDS
.01 - .06 - .97 - Z-Rated

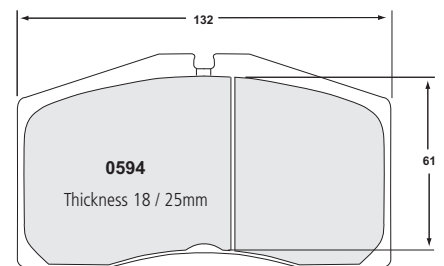

COMPOUNDS
.01 - .06 - .08 - .97

PERFORMANCE[®] FRICTION BRAKES

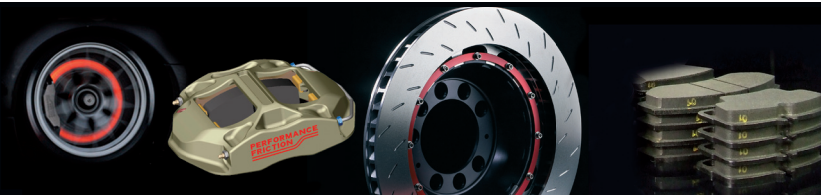

PORSCHE BRAKE APPLICATIONS

PAD PROFILES

PAD COMPOUNDS AVAILABLE



Carbon Metallic[®]

PART NUMBERING AS FOLLOWS:

Pad Shape **0031** Compound **.97** Total Thickness **.15** (mm)

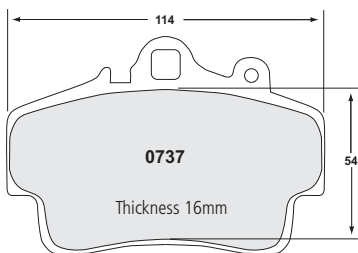

COMPOUNDS
.01 - .97

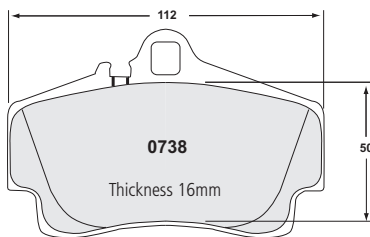

COMPOUNDS
.01 - .06 - .97

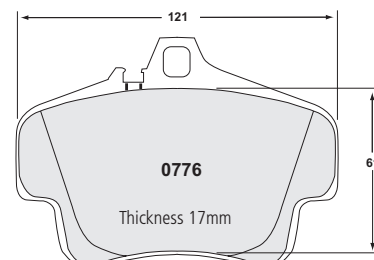

COMPOUNDS
.01 - .06 - .97

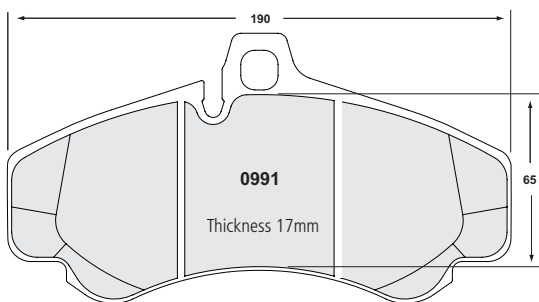

COMPOUNDS
.08

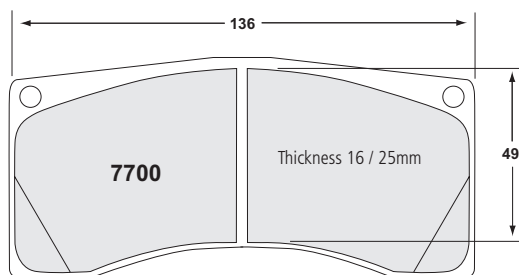

COMPOUNDS
.01 - .06 - .08 - .97

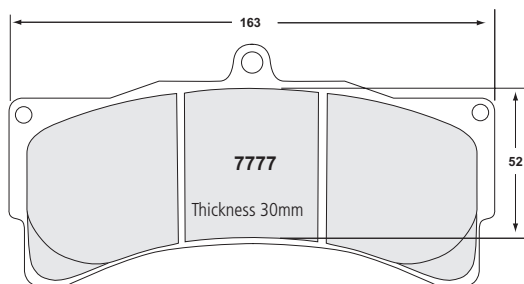

COMPOUNDS
.01 - .06 - .08

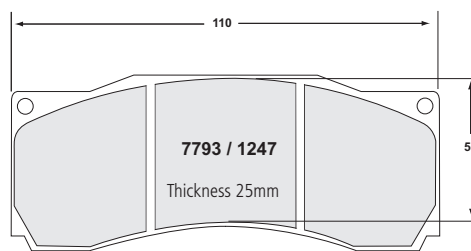

COMPOUNDS
.01 - .06 - .08 - Z-Rated

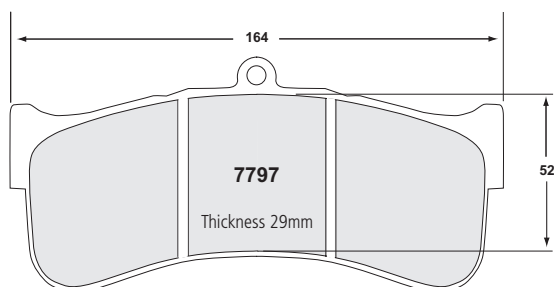

COMPOUNDS
.01 - .06 - .08 - .97

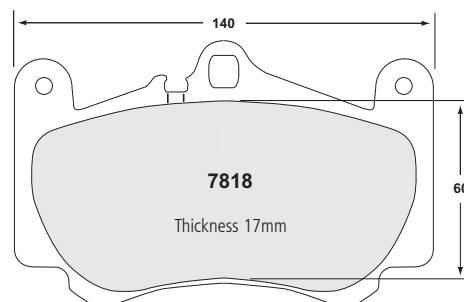

COMPOUNDS
.01 - .97

PORSCHE BRAKE APPLICATIONS

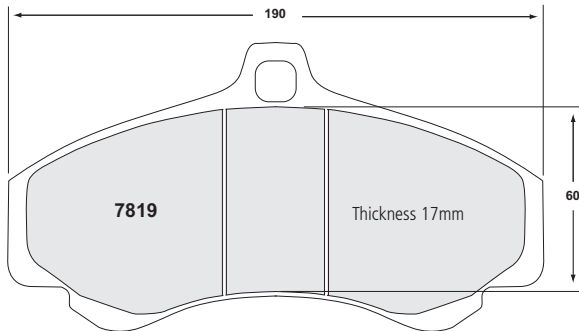

COMPOUNDS
.01 - .06 - .08 - .97

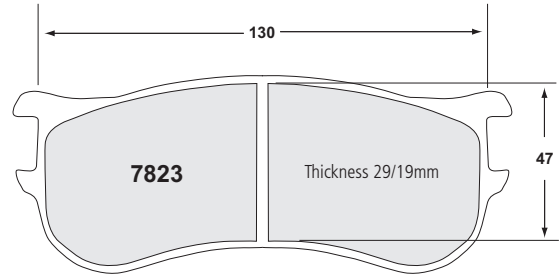

COMPOUNDS
.01 - .06 - .07 - .08 - .97

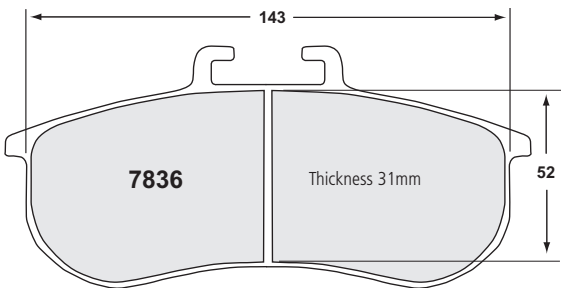

COMPOUNDS
.01 - .06 - .07 - .08 - .97

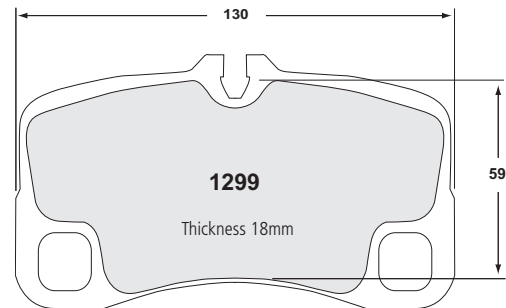

COMPOUNDS
.01 - .06 - .08

REPLACEMENT DISCS

MODEL	YEAR	DISC ASSEMBLY / REPLACEMENT DISCS			PAD
996, 997 C2, C4, Boxster inc S, Cayman inc S & R	1999 - Front	Dimpled Disc & hat Assembly	318mm x 28mm	318.067.87/8	0776 - 17mm
		Replacement disc & fitting for above	318mm x 28mm	318.28.0061.87/88	
996 GT3, 997 GT3, 997 GTRS (non turbo)	2004 - Front	Dimpled Disc & hat Assembly	350mm x 34mm	350.068.87/88	7819 - 17mm
		Replacement disc & fitting for above	350mm x 34mm	350.34.0060.87/88	
		Slotted Disc & hat Assembly	350mm x 34mm	350.068.67/68	7819 - 17mm
		Replacement disc & fitting for above	350mm x 34mm	350.34.0060.67/68	
996 Cup With Centre Lock Wheels	2002 - Front	Hat with 16.5mm holes to suit drive peg wheels		206.157.269.12	7819 - 17mm
		Disc & fitting for above	350mm x 34mm	350.34.0060.67/68	
997, GT3, PCCB and Std Replacment 16.5mm wheel stud hole	2004 - Front	Dimpled Disc & hat Assembly (V2 drive system)	379mm x 34mm	379.067.85/86	0991 - 17mm
		Replacement disc for above	379mm x 34mm	379.34.0066.43/44	
997, GT3, PCCB and Std Replacment Suits Road Centre Lock wheels 15.5mm wheel stud hole	2010 - Front	Dimpled Disc & hat Assembly (V2 drive system)	379mm x 34mm	379.068.85/86	0991 - 17mm
		Replacement disc for above	379mm x 34mm	379.34.0066.43/44	
997 Turbo, PCCB and Std Replacment Suits Road Centre Lock wheels 15.5mm wheel stud hole	2010 - Front	Dimpled Disc & hat Assembly (V2 drive system)	379mm x 34mm	379.069.85/86	0991 - 17mm
		Replacement disc for above	379mm x 34mm	379.34.0066.43/44	
997, Inc Turbo PCCB and Std replacment Retains std handbrake assembly	2006 - Rear	Dimpled Disc & hat Assembly (V2 drive system)	348mm x 29mm	348.076.85/86	1299 - 18mm
		Replacement disc for above	348mm x 29mm	348.29.0060.43/4	

PERFORMANCE FRICTION BRAKES



PORSCHE BRAKE APPLICATIONS



Carbon Metallic®

RACE DISCS - FRONT

MODEL	SPEC	CALIPER	PAD	HAT	DISC	BOBBIN
996 GT2	Endurance	PFC ZR27	7836 - 31mm	PFC V2 240.155.385.13	PFC 378.35.0051.45/46	na
	Sprint	PFC ZR27	7836 - 31mm	PFC V2 240.155.385.13	PFC 378.32.0051.45/46	na
996 GT3R		Brembo 4 pot OE Porsche	0594 - 25mm	Brembo / Porsche	PFC 378.32.0060.03/04	Brembo Pin type
		Brembo 4 pot OE Porsche	0594 - 25mm	PFC 237.103.029.01	PFC 378.32.0060.01/02	PFC 900.700.003.01
996 GT3 RS	Endurance	Brembo 6 pot motorsport	7797 - 29mm	Brembo / Porsche	PFC 378.35.0051.03/04	Brembo Pin type
	Endurance	Brembo 6 pot motorsport	7797 - 29mm	PFC 256.103.281.01	PFC 378.35.0051.01/02	PFC 900.700.003.01
	Endurance	AP 6 pot monobloc	7777 - 30mm	AP / Porsche	PFC 378.35.0051.03/04	Ap mtg kit
	Endurance	AP 6 pot monobloc	7777 - 30mm	PFC 256.103.281.01	PFC 378.35.0051.01/02	PFC 900.700.003.01
	Endurance	PFC ZR27	7836 - 31mm	251.157.310.12	PFC 378.35.0051.07/08	PFC 900.700.775.02
	Sprint	Brembo 6 pot motorsport	7797 - 29mm	Brembo / Porsche	PFC 378.32.0051.03/04	Brembo Pin type
	Sprint	Brembo 6 pot motorsport	7797 - 29mm	PFC 256.103.296.01	PFC 378.32.0051.01/02	PFC 900.700.003.01
	Sprint	AP 6 pot	7793 - 25mm	AP / Porsche	PFC 378.32.0051.03/04	Ap mtg kit
	Sprint	AP 6 pot	7793 - 25mm	PFC 256.103.296.01	PFC 378.32.0051.01/02	PFC 900.700.003.01
	Sprint	PFC ZR27	7836 - 31mm	251.157.310.12	PFC 378.25.0051.07/08	PFC 900.700.675.02
	996 GT3 RS	Cup	Brembo 6 pot OE Porsche	7819 - 17mm	Brembo / Porsche PFC 237.103.029.01	PFC 378.32.0060.03/04 PFC 378.32.0060.01/02
997 GT3	Cup - 2008 -	Brembo 6 pot OE Porsche	7819 - 17mm	Brembo / Porsche PFC 237.103.029.01	PFC 378.32.0060.03/04 PFC 378.32.0060.01/02	Brembo Pin type PFC 900.700.003.01
997 GT3	Cup & S 2008 -	Brembo 6 pot OE Porsche	7819 - 17mm	Brembo / Porsche PFC 237.103.029.01	PFC 378.32.0060.03/04 PFC 378.32.0060.01/02	Brembo Pin type PFC 900.700.003.01
997 GT3	Cup Australia	Brembo 6 pot OE Porsche	7819 - 17mm	PFC V2 219.157.272.13	PFC 378.34.0060.45/46	na
997 GT3 RSR	Endurance	PFC ZR27	7836 - 31mm	PFC V2 240.155.385.13	PFC 378.35.0051.45/46	na
	Sprint	PFC ZR27	7836 - 31mm	PFC V2 240.155.385.13	PFC 378.32.0051.45/46	na

RACE CALIPERS

ZR22 AND ZR27 - PERFORMANCE FRICTION RACING CALIPERS

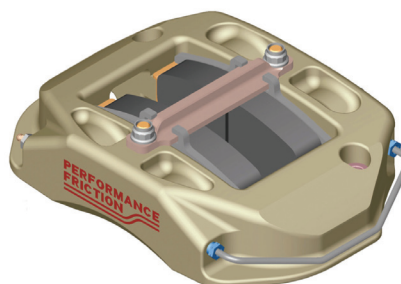
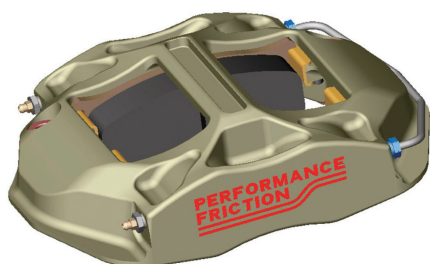

Full specifications and build sheets available. Please contact our technical sales department for detailed advice.



Carbon Metallic[®]

RACE DISCS - REAR

CALIPER	PAD	HAT	DISC	BOBBIN
PFC ZR22	7823 - 29mm	PFC V2 223.155.430.13	PFC V2 355.32.047.45/46	na
PFC ZR22	7823 - 29mm	PFC V2 223.155.430.13	PFC V2 355.30.047.45/46	na
Brembo 4 pot motorsport	7700 - 25mm PFC 237.103.030.01	Brembo / Porsche PFC 355.32.0048.05/06	PFC 355.32.0048.03/04 PFC 900.700.003.01	Brembo Pin type
Brembo 4 pot motorsport	7700 - 25mm	Brembo / Porsche PFC 237.103.030.01	PFC 355.32.0048.03/04 PFC 355.32.0048.05/06	Brembo Pin type PFC 900.700.003.01
PFC ZR22	7823 - 29mm	PFC 230.157.325.12	PFC 355.32.0047.07/08	PFC 900.700.575.02
Brembo 4 pot motorsport	7700 - 25mm	Brembo / Porsche PFC 237.103.030.01	PFC 355.32.0048.03/04 PFC 355.32.0048.05/06	Brembo Pin type PFC 900.700.003.01
PFC ZR22	7823 - 29mm	PFC 230.157.325.12	PFC 355.32.0047.07/08	PFC 900.700.575.02
Brembo 4 pot OE Porsche	0776 - 17mm	na	Brembo 350mm 1 peice	na
Brembo 4 pot OE Porsche	1299 - 18mm	na	Brembo 350mm 1 peice	na
Brembo 4 pot OE Porsche	1299 - 18mm	na	Brembo 350mm 2 peice	T Bobbin
Brembo 4 pot OE Porsche	1299 - 18mm	PFC V2 203.157.395.13	PFC 348.29.0060.45/46	na
PFC ZR22	7823 - 29mm	PFC V2 223.155.423.13	PFC 355.32.0047.45/46	na
PFC ZR22	7823 - 29mm	PFC V2 223.155.423.13	PFC 355.30.0047.45/46	na

PFC V2 DIRECT DRIVE SYSTEM

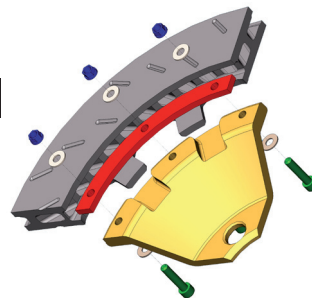

Performance Friction Europe

Carbon Metallic House, Wildmere Road, Banbury, Oxon OX16 3LU United Kingdom
 Tel: +44(0)1295 221020 Fax: +44(0)1295 279711
 uksales@performancefriction.com www.performancefriction.com

PERFORMANCE[®] FRICTION BRAKES



Carbon Metallic[®]

HOW TO FIND US

Our European Headquarters located at Banbury in Oxfordshire is extremely well serviced by road, rail and air transport.

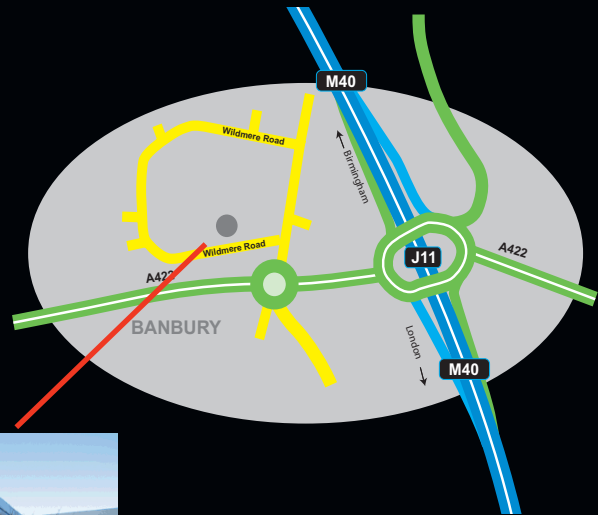

Performance Friction Europe

Carbon Metallic House, Wildmere Road,
Banbury, Oxon OX16 3LU
United Kingdom

Tel: +44(0)1295 221020 Fax: +44(0)1295 279711

uksales@performancefriction.com
www.performancefriction.com